

# PRESSTITE

MULTI-LAYER PIPE & PRESS FITTING SYSTEM

PRODUCT CATALOGUE  
EFFECTIVE FROM 1<sup>ST</sup> JANUARY 2013



# Introduction to Presstite

Presstite Multilayer is a composite pipe system using the advantages of PE-X technology with the positive features of an aluminium inner pipe. This gives a large degree of flexibility and toughness while utilising high temperatures and pressures.

Presstite is designed for potable water, sanitary and heating applications. With both WRAS and DVGW approval, Presstite is ideally suited for installations on both domestic and commercial applications.

The specially designed press fitting comprises a brass body and a stainless steel sleeve range from (16mm - 63mm)

Fittings are compressed onto the pipe using a battery powered press-fit tool. This method of jointing takes a fraction of the time that is generally associated with traditional soldering and compression methods.

Press-fit technology has been widely used in Europe for more than twenty years and has become increasingly popular in Ireland over the past decade.

## Features and Benefits

The Presstite system offers a number of key advantages when compared to both traditional materials and similar products.

- Faster installation, small bend radii possible and easy pipe laying
- Press-fittings require no soldering, welding or thread cutting
- Heat free jointing which eliminates the necessity for Hot Works
- Quick, simple efficient jointing method resulting in installed cost reductions
- Resistant to temperature and pressure requirements in drinking water and heating applications
- Hygienic and material neutral, even if high pH value fluctuations in drinking water should occur
- Corrosion-free for long service life
- Light in weight when compared to screwed steel products.
- Thermal Expansion is comparable with copper
- Low recyclable value - reduced on site risk of theft

## Quality

The Presstite system is approved by the following regulatory bodies.

ISO 9001 certification all production steps and quality controls are specified precisely according to ISO 9001 so that uniform product quality is ensured.



### UK & Ireland Netherlands

WRAS approved



### Germany

DVGW approved



### The

KIWA (Complying with ISO21003)



## Applications

Presstite can be used on potable water, hot and cold water, heating installations and also fan coil units.

It can be installed in domestic applications both in new and existing buildings. Presstite is also ideally suited for apartment blocks and hotels. It can be used in projects where the use of gas is not permitted for brazing such as existing hospital refurbishments or even pharmaceutical applications.

# Table of Contents

page 04

## The System

[Multilayer Pipe](#)

[Press Fittings](#)

page 05 - 16

## Presstite Multilayer Technical Information

[Technical Properties](#)

[Pressure Drop Graph - Heating Applications](#)

[Pressure Drop Graph - Sanitary Applications](#)

[Thermal Linear Expansion](#)

[Thermal based elongation](#)

[Clip spacing for freely laid pipes](#)

[Bend Behaviour](#)

[Length changing in freely laid pipes](#)

[Expansion loops](#)

[Regulations for insulation of tap water- and heating installations](#)

[Technical Instructions: Sanitary](#)

[Performance curve](#)

[Pressure loss chart](#)

[Technical Instructions: Heating](#)

[Press loss due to pipe friction for Presstite pipe](#)

[Calculation and tender](#)

page 17

## Connecting Pipe & Fittings

page 18 - 29

## Presstite Multilayer Product Guide

# The System

## Multilayer Pipe

The multilayer pipe is manufactured by Hewing Germany, a global market leader in the production of crosslinked polyethylene pipe (PE-Xc pipes).

Hewing is also a market leader in multilayer pipe, every day producing several hundred thousand metres of pipe.

Hewing represents quality and environmental management, certified pursuant to DIN EN ISO 9001 and DIN EN ISO 14001.

Each of the four layers (PE-X/adhesive/adhesive/PE-X coating) of the Multilayer pipe is produced by a separate extruder.

This means that the layer thicknesses of the individual layers can be precisely set and controlled, in contrast to other production processes.

The aluminium pipe embedded in the PE-X layers is formed from an aluminium band using a special roll handling process.

The aluminium layer determines the good form stability and high internal pressure resistance of the multilayer pipe.

The thickness of the aluminium layer is precisely calculated according to the pipe diameter.

The aluminium band is butt welded without overlap using the WIG welding process.

This creates a highly durable and homogeneous aluminium pipe with uniform layer thickness across the entire pipe circumference. This enables, e.g. expansion of the multilayer pipes and the production of particularly tight bends of up to 1.5 x d.

## Press Fittings

The press fittings are manufacture by IPA in Austria. The fittings are constructed as radial press connection elements with multiple joints and therefore guarantee a durable and tight connection with the pipes.

The fitting is made of dezincification brass. The press sleeve is made of stainless steel and is equipped with viewing windows to control the depth for tube plug in. This is connected to the fitting by means of an insulated ring.

All the materials that could be in contact with potable water fulfil all requests of the standards DVGW W 534 and DVGW W 270.



## Pipe Properties

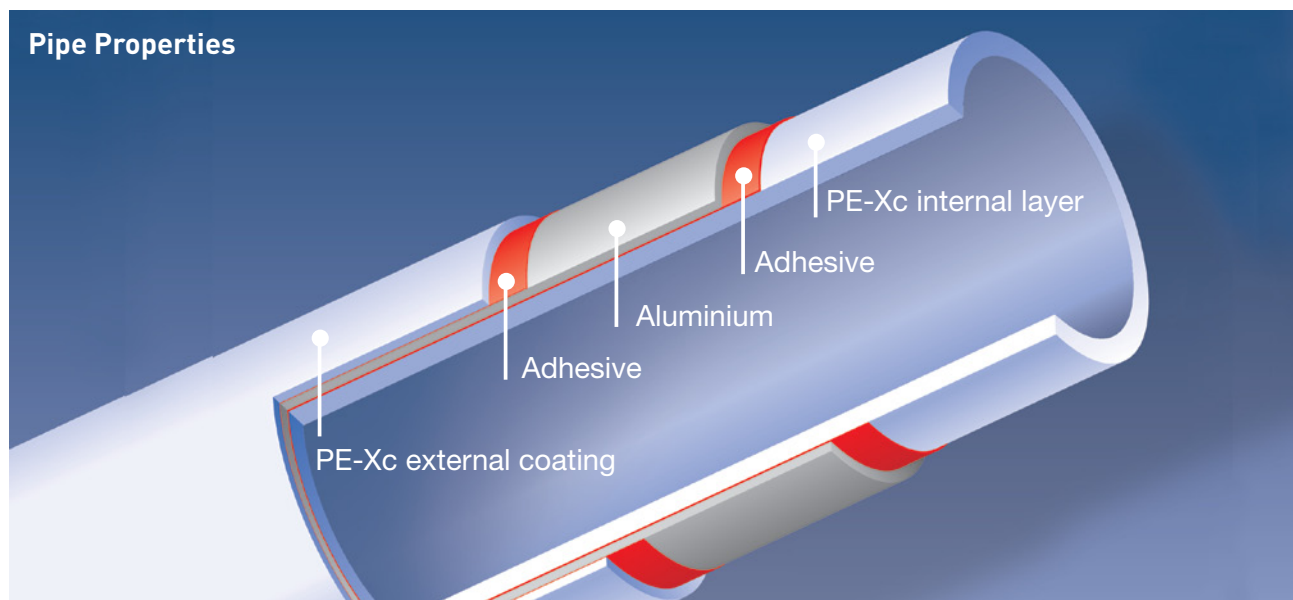

# Technical Information

## Technical Properties of Presstite Multilayer Pipes

Pipe dimensions in mm	16 x 2	20 x 2	26 x 3	32 x 3	40 x 3.5	50 x 4	63 x 4.5
Outer diameter Nominal size in mm	16	20	26	32	40	50	63
Wall thickness Nominal size in mm	2	2	3	3	3.5	4	4.5
Inner diameter Nominal size in mm	12	16	20	26	33	42	54
Pipe weight in g/m	125	166	298	393	605	870	1315
Pipe weight with water in g/m	238	358	612	924	1460	2255	3605
Internal volume in l/m	0.113	0.201	0.314	0.531	0.855	1.385	2.290
Heat conductivity in W/m·K <sup>1)</sup>	0.43	0.43	0.43	0.43	0.43	0.43	0.43
Coefficient of expansion in mm/m·K	0.024	0.024	0.024	0.024	0.024	0.024	0.024
Surface roughness [internal pipe] in µm	1.5	1.5	1.5	1.5	1.5	1.5	1.5
Oxygen diffusion in mg/l·d	0	0	0	0	0	0	0
max. operating temperature in °C	95	95	95	95	95	95	95
max. operating pressure [at 95°C] in bar	10	10	10	10	10	10	10
Short-term pressure [at 95°C] in bar	15	15	15	15	15	15	15
Bending radius free bending	≥ 5 x D	≥ 5 x D	≥ 5 x D	≥ 5 x D	≥ [5 x D]	≥ [5 x D]	≥ [5 x D]
Bending radius bent with bending die	≥ 1.5 x D*	≥ 3.5 x D	≥ 3.5 x D	≥ 3.5 x D	≥ 3.5 x D	≥ 3.5 x D	≥ 3.5 x D

\* with special tool; <sup>1)</sup> Mean value

All values are guide values only; further pipe dimensions on request.

## Pressure Drop Graph - Heating Applications

The values are calculated using the pipe wall roughness  $k = 0.0015$  mm determined for Presstite multilayer pipe. (DIN 1988 Part 3)

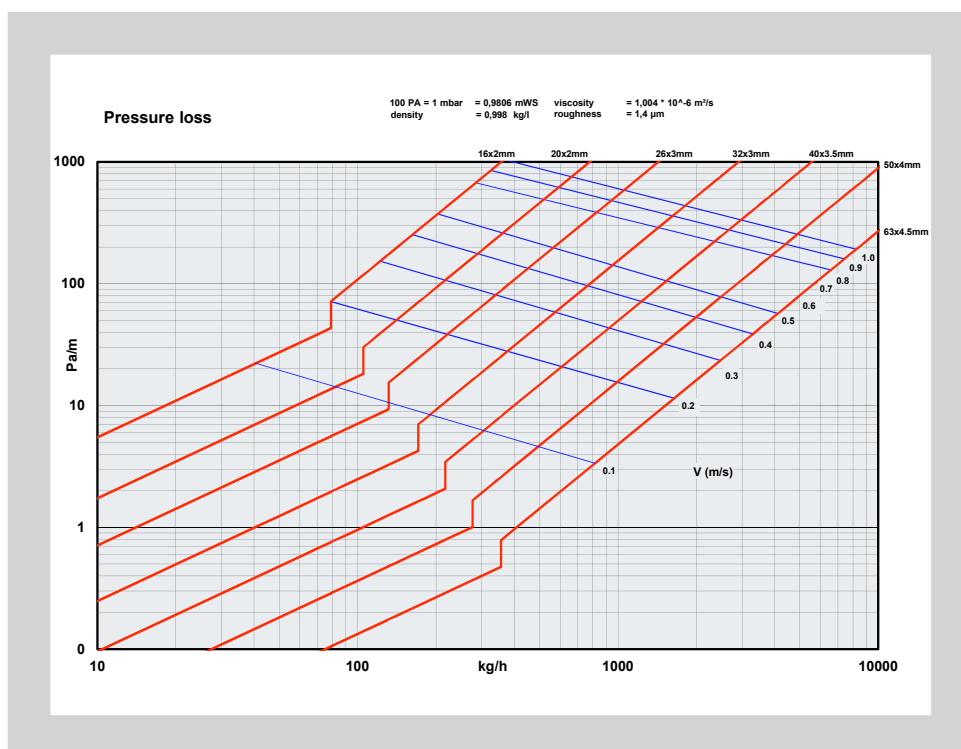



### Pressure Drop Graph – Sanitary Applications

Values are calculated using the pipe wall roughness  $k = 0.007$ , as per DIN 1988, Part 3.

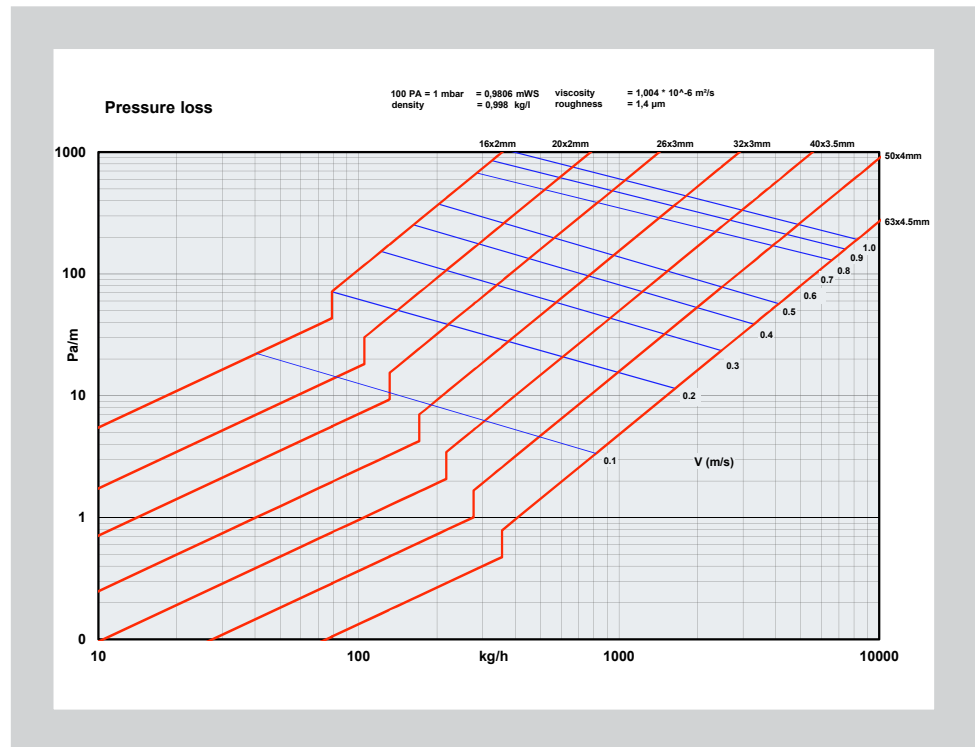

### Thermal Linear Expansion

Like all pipe Presstite Multilayer expands when heated and contracts when cooled. This expansion of the pipe must be taken into account when designing a system.

The linear coefficient of expansion of Presstite Multilayer is, independent of the pipe dimension, 0.024 m/mK.

The expected elongation of Presstite Multilayer in operation can be determined in the following graph for different pipe lengths and temperature differences.

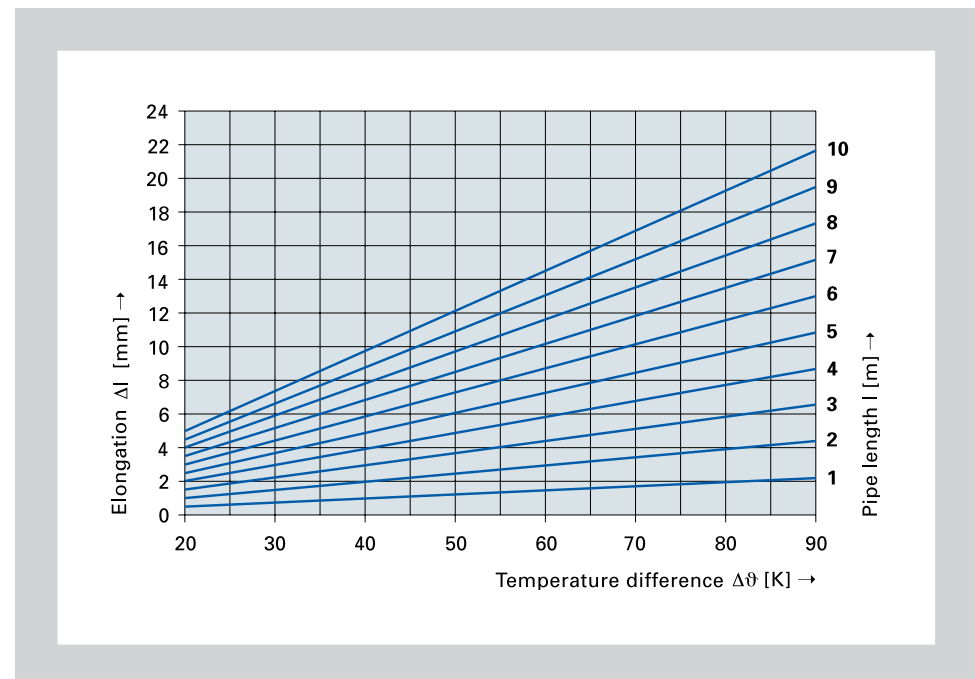

The elongation can also be calculated using the following equation:

$$\Delta l = \alpha \times l \times \Delta \vartheta$$

$\alpha$  = Linear coefficient of expansion (mm/m·K)

$l$  = Installed pipe length (m)

$\Delta \vartheta$  = Temperature difference (e.g. between installation temperature and maximum operating temperature [K]).

## Thermal based expansion

Measures for avoiding damage caused by thermal based expansion vary depending on the installation situation.

### Example 1: Expansion

$l = 5 \text{ m}$  (pipe length between two bends)

$\Delta v = 60 \text{ K}$  (temperature difference between installation temperature and maximum operating temperature)  
from the elongation graph

7.2 mm (linear expansion of pipe section).

This means that 3.6 mm pipe expansion must be compensated for on both sides.

### Pipes in concrete or screed (note sound insulation)

Because of the relatively low expansion forces, compensation measures are not required for direct embedding of pipes.

The easy plastic formability of the Presstite Multilayer means that the length changes are absorbed by the pipe wall.

### Pipes in floor insulation layers

As the Presstite Multilayer pipes laid in insulations layers can move axially without great resistances, the expected elongation changes must be compensated for.

Right-angled direction changes of the pipe in the insulation layer must be arranged so that the expected elongation of each partial section can be absorbed by the insulation at the bend area.

### Pipes laid under plaster

Depending on the wall structure and brickwork strength, there is a danger that the expansion forces of a Presstite Multilayer pipe embedded directly in the plaster could cause damage to the wall.

Therefore, Presstite Multilayer pipes that are laid under plaster must be fitted with a sleeve that is capable of absorbing the expected thermal based elongation. In those cases where Presstite Multilayer pipes laid under plaster is already heat insulated or condensation water protected, this insulation is generally sufficient to compensate for the thermal based elongation.

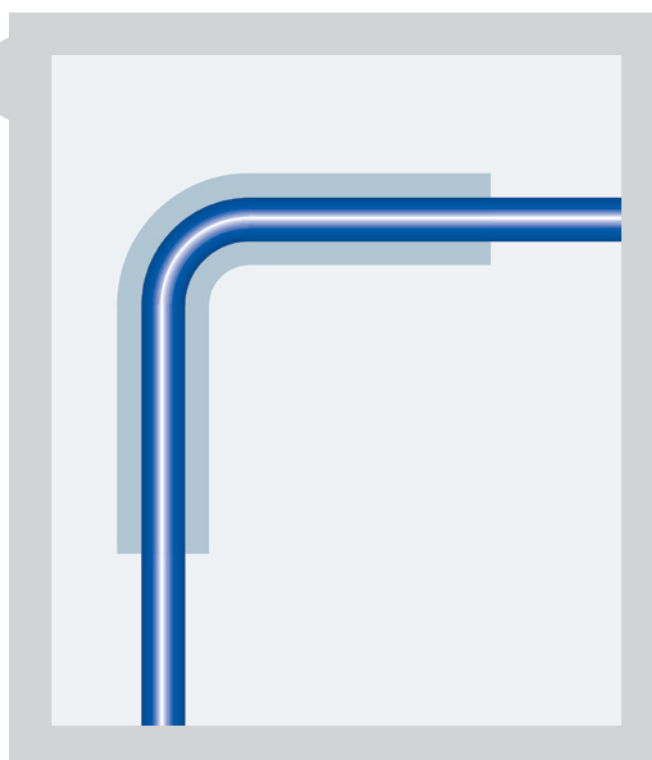
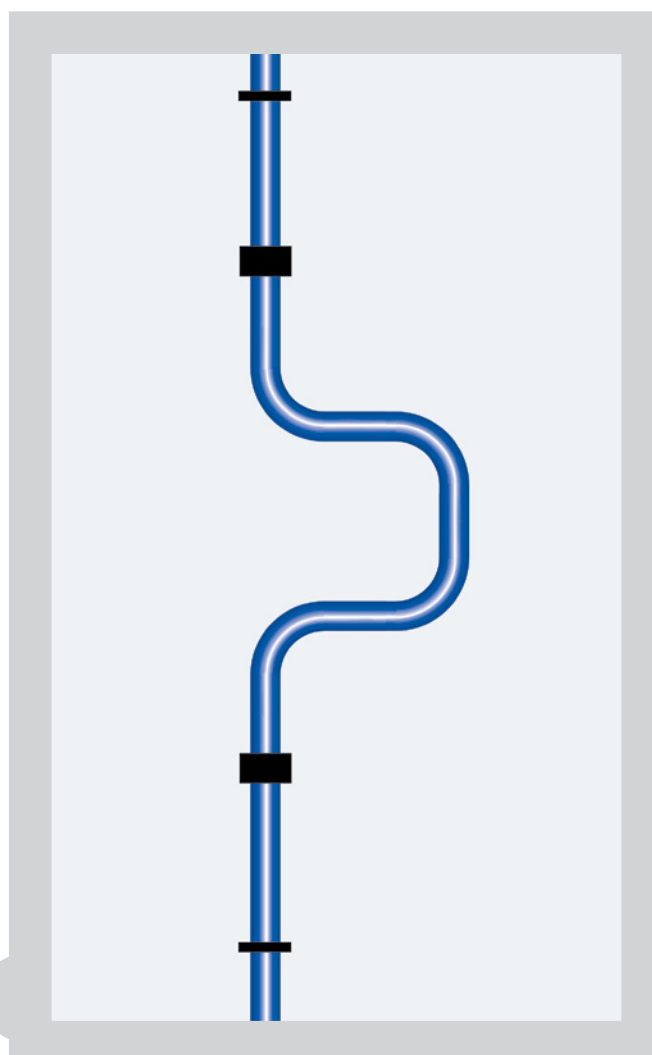

**Freely laid pipes**

With freely laid pipes (e.g. cellar pipes, risers, etc.) the thermal based elongation in the Presstite Multilayer pipes must be taken into account according to the rules of pipe engineering, e.g. by arranging U-shaped bends in combination with fixed points and plain bearings.

**Example 2 Calculation of Compensation with Bend Joints (BJ)**

- $l = 5 \text{ m}$  (pipe length between fixed point and change of direction)
- $D_o = 26 \text{ mm}$  (outer diameter of Presstite Multilayer pipe)
- $\Delta\vartheta = 60 \text{ K}$  (temperature difference)
- $c = 33$  (dimensionless material constant)
- $\Delta l = 7.2 \text{ mm}$  (linear expansion of pipe section)

$BJ = c \cdot \sqrt{D_o \cdot \Delta l}$

**Bend Joint Length Required = 451.11mm**

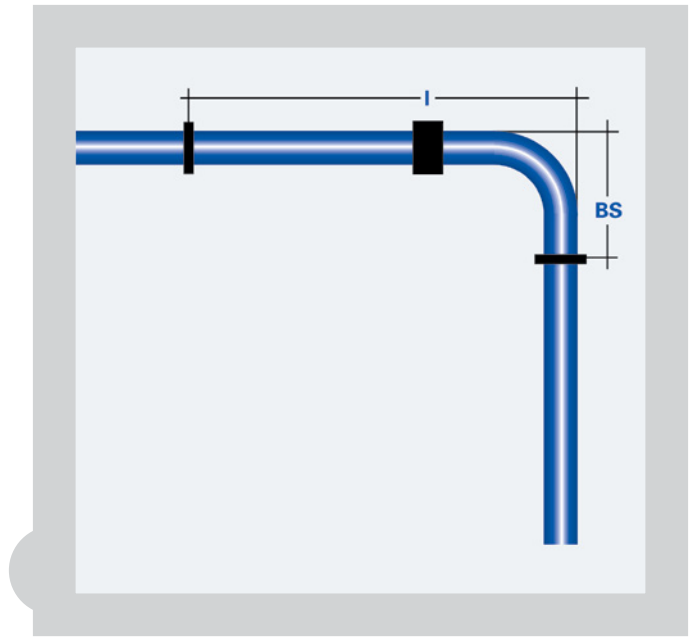

**Example 3 Determining Bend Joints from Graph:**

- $D_o = 26 \text{ mm}$  (external diameter of Presstite Multilayer pipe)
- $\Delta l = 10 \text{ mm}$  (linear expansion of pipe section)
- Read from the graph:
- $BJ = 530 \text{ mm}$

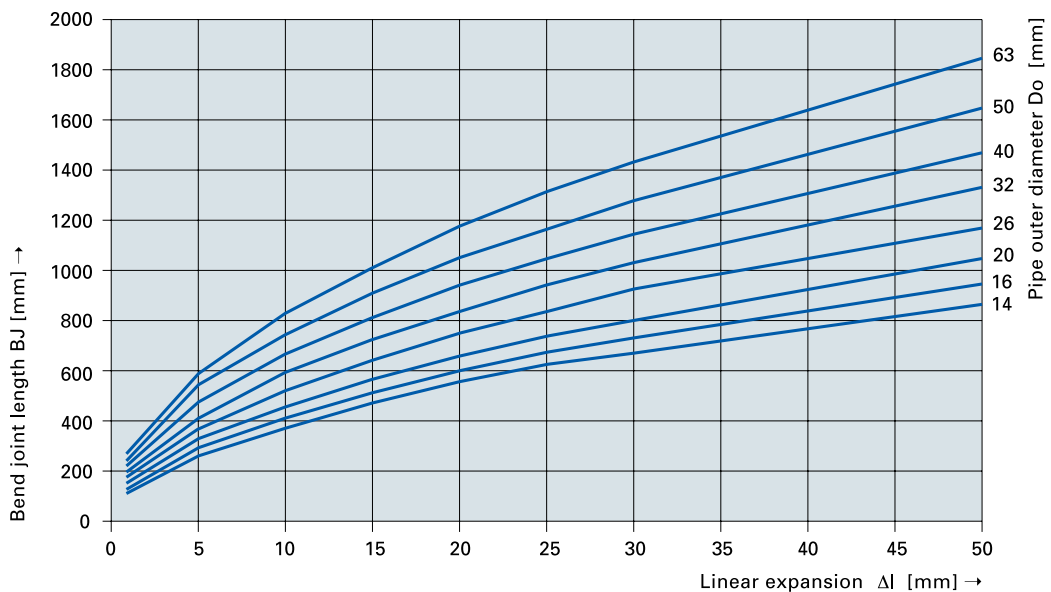



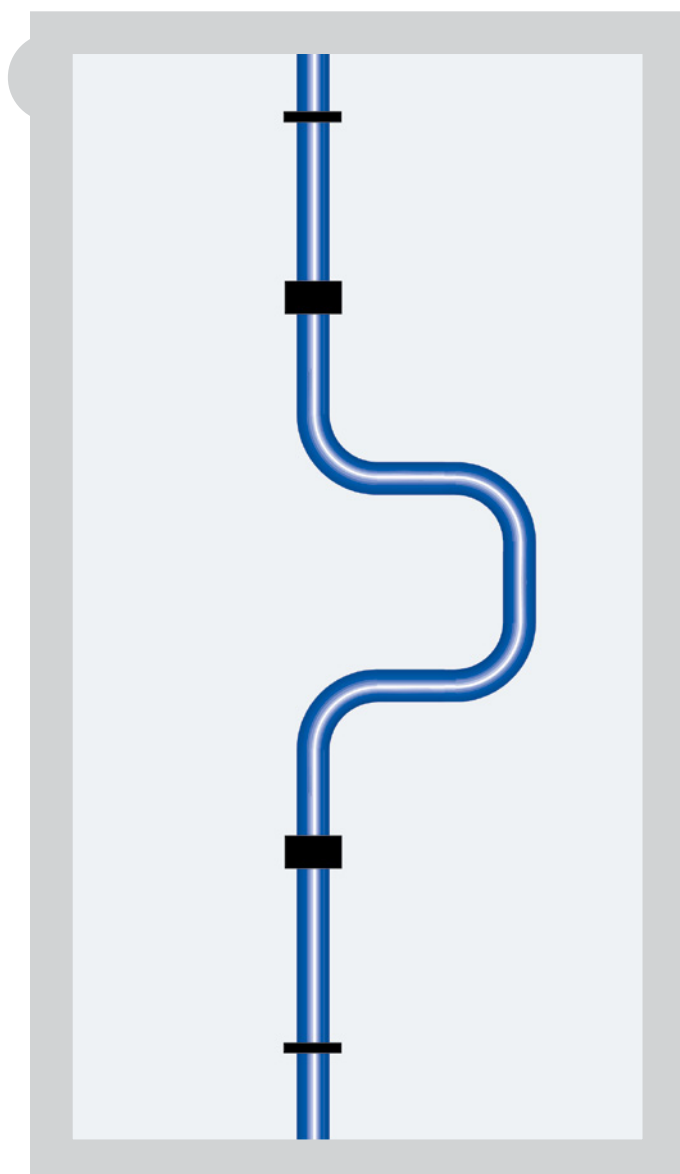

## Clip spacing for freely laid pipes

### Example 4: Compensation by U-pipe bends

#### Installation distances

Freely laid Presstite Multilayer pipe does not require supporting aids such as support shells, support pipes, etc. because of their shape stability.

They can be fastened in place with the clip distances B given in the diagram below.

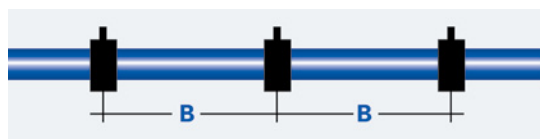

$L1 = 6 \text{ m}$  (length of the partial section 1)

$L2 = 6 \text{ m}$  (length of the partial section 2)

$D_o = 26 \text{ mm}$  (outer diameter of Multilayer)

$\Delta\vartheta = 60 \text{ K}$  (temperature difference)

$c = 33$  (dimensionless material constant)

$\Delta l = 8.64 \text{ mm}$  (linear expansion of pipe section 1)

$\Delta 2 = 8.64 \text{ mm}$  (linear expansion of partial section 2)

Required: Bend joint length:

$$BJ = c \cdot \sqrt{D_o} \cdot \Delta l$$

$$BJ = 494.6 \text{ mm}$$

#### Fixing distances for Hewing MT multilayer pipes

Dimension mm	16	20	26	32	40	50	63
Distance B m	1	1	1.5	2	2	2.5	2.5

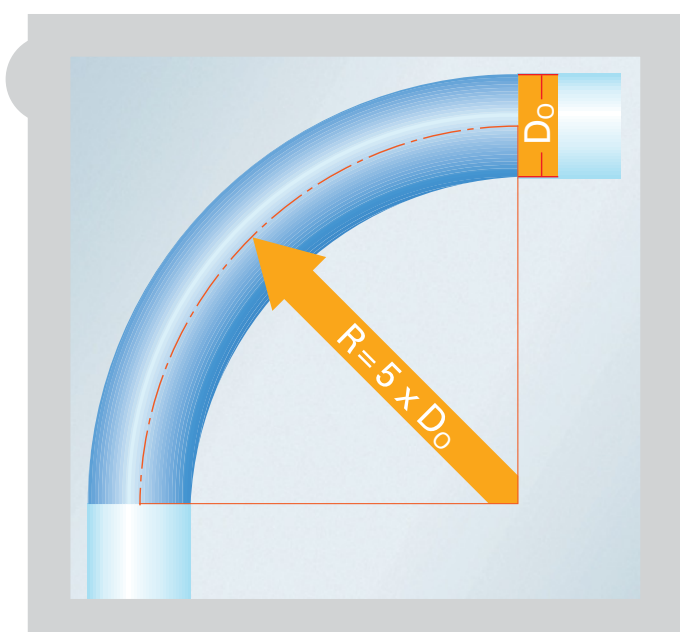

## Bend Behaviour

Multilayer pipe in contrast to steel and copper pipes can be easily bent by hand. This is a particular advantage when further bending is required by hand in difficult to access areas.

Because of the possible tight bend radii (up to  $1.5 \times D_o$  with spiral spring for  $16 \times 2 \text{ mm}$  dimensions; up to  $5 \times D_o$  by hand)

Multilayer pipes can be bent in the smallest of areas which often means that expensive forming equipment is not required.

Despite its good bending ability, the pipe is very shape stable which enables longer fixing distances.

### Length changing in freely laid pipes

The thermal lengthways expansion is generally regulated by means of an applicable pipeline guide (flexible bend for changes in direction resp. application of expansion equalizers (expansion loops and compressors). The choice and order of pipe-fixing units (sliding sleeves and fixed points) depends on the assembly situation.

A laying of the pipe with flexible bends as lengthways adaptors results automatically due to the changes in direction resp. from the right angled connections by correct fitting of sliding and fixed points.

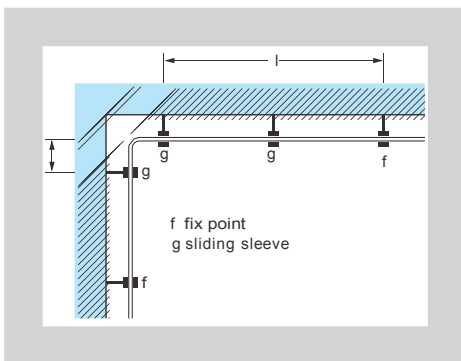

### Fixing technique- Fixing distance

Maximum pipe sleeve fixing distance from Presstite connecting pipes:

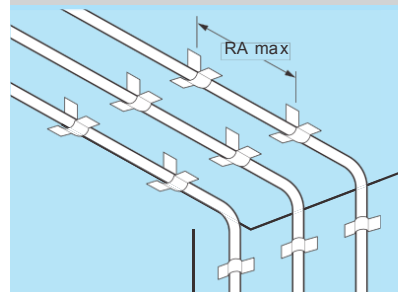

Dim.	DN	RA [cm]
16	12	100
20	15	125
26	20	150
32	26	200
40	32	200
50	42	200
63	54	200

### Determination of the flexible bend length

The lengthways change and the outer diameter does influence the flexible bend length.

Calculation of flexible bend

The minimum flexible bend can be taken from the diagram by help of the following formula:

- $b = k \times (d \times \Delta l) 0,5$
- $b =$  Length of flexible bend
- $d =$  external diameter in [mm]
- $\Delta l =$  lengthways expansion in mm
- $k =$  material dependent constant (MT-pipe = 33)

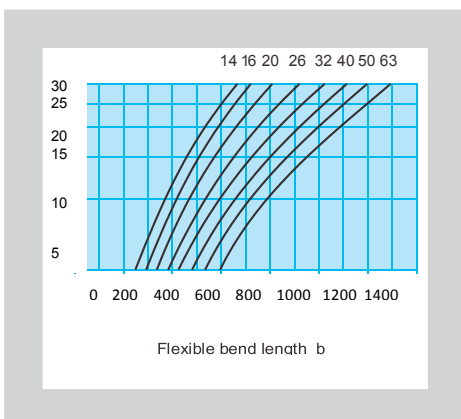

For Presstite sanitary pipes laid straight into the floor a fixing distance of 1,0m is applicable. 0,3 m before and after a 90° bend a fixing with anchor fittings is necessary

### Pipe installation in risky areas

When laying Presstite pipes in risky areas e.g. due to aggressive gases or permanent impact of humidity it is only necessary to protect the metal compound.

### Expansion loops

Example for calculation:

Required value: length of flexible bend

Given value: lengthways expansion

$\Delta l = 10$  mm  
External pipe

diameter

$d = 26$  mm

Solution :

$b = 530$  mm

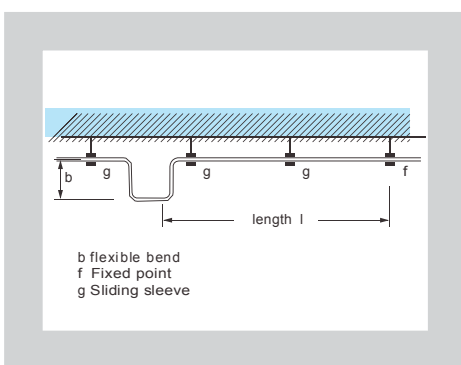

## Regulations for insulation of tap water- and heating installations

### Cold water pipes

According to DIN 1988 part 2 the tap water pipes (cold) have to be protected to avoid heating and condensation water formation.

The indicative values for the minimum Insulation layers related to WLG 040 can be taken from the table. Here the minimum requirements for heating systems regulations for energy saving rules are applicable.

### Indicative values for minimum insulation thickness for tap water (cold)

Installation situation	Insulation thickness at $\lambda = 0,040 \text{ W/mK}$ mm
Pipes freely laid in not heatable rooms (e.g. basement)	4
Pipes freely laid in heatable rooms	9
Pipes in chanel without hot water pipes	4
Pipes in chanel next to hot water pipes	13
Pipes in a pipe chase rise	4
Pipes in a pipe chase rise besides hot water pipes	13
Pipes on concrete flooring	4

\*For other thermal conductivity the insulation layer thickness should be adapted, related to the diameter of 20 mm.

Extract: Regulation about energy saving thermal insulation and energy saving installation techniques in buildings (EnEV)

### Hot water pipes (process water and heating)

#### Distribution device and hot water pipes

When heat distribution - and hot water pipes as well as armatures are installed in buildings for the first time or when existing have to be replaced, their heat emission has to be reduced.

The heat emission of heat distributor- and hot water pipes as well as armatures has to be limited with heat insulation according to requirements of chart 1.

Line	Type of pipes/armatures	Minimum thickness of insulation, related to the heat conductivity of $0,035 \text{ W/mK}$
1	Internal diameter to 22mm	20mm
2	Internal diameter over 22 to 35mm	30mm
3	Internal diameter over 35 to 100mm	equal inndiameter
4	Internal diameter more than 100mm	100mm
5	Pipes and armatures acc. To line 1 to 4 in wall-and ceiling breaks, in intersection areas of pipes, at pipe connection parts, at central pipe system distributors	1/2 of requirements of line 1 to 4
6	pipes and armatures acc. To line 1 to 4 after this regulation has been established, are in layer in construction parts between heated construction elements	1/2 of requirements of line 1 to 4
7	Pipes acc. to line 6 in floor construction	6mm

As far as pipes of central heatings are located in heated rooms or in construction units between a user and the heat output can be influenced by freely laying shut-off device, there are no requirements in regard to the minimum thickness of insulation, according to line

The insulation thicknesses in chart 1 are related to the heat conductivity of  $0,035 \text{ W/mK}$ .

For materials with different heat conductivity groups than  $0,035 \text{ W/mK}$  the minimum insulation thicknesses have to be converted according to chart 1. The calculated values and method of calculation applied in the technical regulations should be applied for the conversion of heat conductivity of the insulation material.

WLG	Insulation material		Insulation thickness [mm] Pipe dimension 16/20	
	Heat coefficient [W/mK]		1/1 Insulation acc. 12 EnEV	1/2 Insulation acc. 12 EnEV
20	0,020		8	4
25	0,025		11	5
30	0,030		15	8
35	0,035		20	10
40	0,040		26	13
45	0,045		33	15

This chart shows required minimum insulation thicknesses for the most used multilayer pipe dimensions,

In which the different heat coefficients thermal conductivities hat to be taken into consideration

## Technical Instructions: Sanitary

Minimum flow pressure and calculation flow rate of common water withdrawal armatures

Water withdrawal point of use	DN	Minimum flow pressure $P_{min FL}$ [bar]	Mixed water withdrawal each		Withdrawal of cold or hot water $\dot{V}_R$ [l/s]
			coldt $V_R$ [l/s]	warm $V_R$ [l/s]	
<b>Kitchen faucets</b>					
Sink –Mixing faucets	DN 15	1	0,07	0,07	~
Washing machine	DN 15	1	~	~	0,25
Dish washer	DN 10	1	~	~	0,15
Drain valve with aerator	DN 15	1	~	~	0,15
<b>Bath faucets</b>					
Bath mixing faucets	DN 15	1	0,15	0,15	~
Shower bath mixing faucets	DN 15	1	0,15	0,15	~
Shower heads	DN 15	1	0,1	0,1	0,2
Sink –Mixing faucets	DN 15	1	0,07	0,07	~
Bidets mixing faucets	DN 15	1	0,07	0,07	~
<b>WC-faucets</b>					
Sistern (acc. DIN 19542)	DN 15	0,5	~	~	0,13
Push button (acc. DIN 3265)	DN 15	1,2	~	~	0,7
Push button (acc. DIN 3265)	DN 20	0,4	~	~	1
Push button (acc. DIN 3265)	DN 25	1	~	~	1
Urinal flusher	DN 15	1	~	~	0,3
<b>Single –tap water heater</b>					
Electrical boiling water device	DN 15	1	~	~	0,1
<b>Special armatures</b>					
Drain valve without aerator	DN 15	0,5	~	~	0,3
Drain valve without aerator	DN 20	0,5	~	~	0,5
Drain valve without aerator	DN 25	0,5	~	~	1
Mixing faucets	DN 20	1	0,3	0,3	~

## Performance curve

For determination of the peak flow ( $V_s$ ) of the sum flow rate  $V_R$  for residential buildings, office- and administration buildings until a sum flow rate of  $\cdot 20$  l/s.

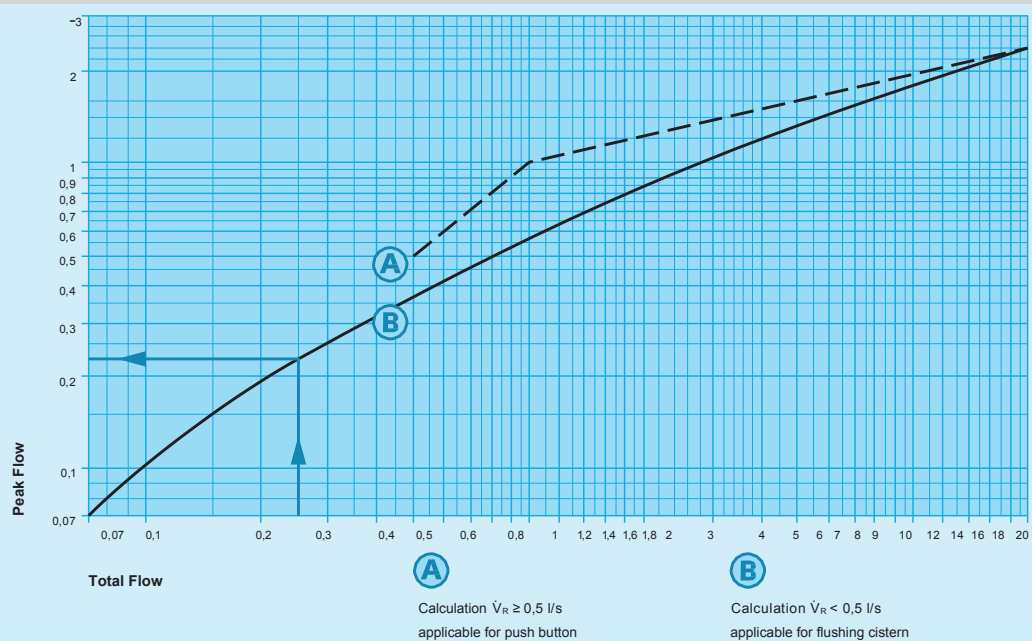

## Pressure loss chart: Sanitary

w m/s	16,0 x 2,0 mm d <sub>i</sub> = 12 mm V̇/l = 0,11 l/m			20,0 x 2,0 mm d <sub>i</sub> = 16 mm V̇/l = 0,20 l/m			26,0 x 3,0 mm d <sub>i</sub> = 20 mm V̇/l = 0,31 l/m			32,0 x 3,0 mm d <sub>i</sub> = 26 mm V̇/l = 0,53 l/m			40,0 x 3,5 mm d <sub>i</sub> = 33 mm V̇/l = 0,85 l/m			50,0 x 4,0 mm d <sub>i</sub> = 42 mm V̇/l = 1,38 l/m			63,0 x 4,5 mm d <sub>i</sub> = 54 mm V̇/l = 2,29 l/m		
	V <sub>s</sub> l/s	m kg/h	R mbar/m	V <sub>s</sub> l/s	m kg/h	R mbar/m	V <sub>s</sub> l/s	m kg/h	R mbar/m	V <sub>s</sub> l/s	m kg/h	R mbar/m	V <sub>s</sub> l/s	m kg/h	R mbar/m	V <sub>s</sub> l/s	m kg/h	R mbar/m	V <sub>s</sub> l/s	m kg/h	R mbar/m
0.10	0.01	41	0.22	0.02	72	0.13	0.03	113	0.08	0.05	191	0.09	0.09	307	0.06	0.14	498	0.05	0.23	823	0.03
0.15	0.02	61	0.33	0.03	108	0.32	0.05	169	0.24	0.08	286	0.17	0.13	461	0.13	0.21	746	0.10	0.34	1234	0.07
0.20	0.02	81	0.75	0.04	144	0.53	0.06	226	0.40	0.11	381	0.29	0.17	614	0.21	0.28	995	0.16	0.46	1645	0.11
0.25	0.03	102	1.11	0.05	181	0.78	0.08	282	0.59	0.13	477	0.42	0.21	768	0.31	0.35	1244	0.23	0.57	2056	0.17
0.30	0.03	122	1.53	0.06	217	1.07	0.09	339	0.81	0.16	572	0.58	0.26	922	0.43	0.42	1493	0.32	0.69	2468	0.23
0.35	0.04	142	2.00	0.07	253	1.40	0.11	395	1.06	0.19	667	0.76	0.30	1075	0.57	0.48	1742	0.42	0.80	2879	0.31
0.40	0.05	162	2.53	0.08	289	1.77	0.13	451	1.34	0.21	763	0.96	0.34	1229	0.72	0.55	1990	0.53	0.92	3290	0.39
0.45	0.05	183	3.11	0.09	325	2.17	0.14	508	1.64	0.24	858	1.18	0.38	1382	0.88	0.62	2239	0.65	1.03	3702	0.47
0.50	0.06	203	3.74	0.10	361	2.61	0.16	564	1.98	0.27	953	1.42	0.43	1536	1.06	0.69	2488	0.78	1.14	4113	0.57
0.55	0.06	223	4.42	0.11	397	3.09	0.17	621	2.33	0.29	1049	1.68	0.47	1690	1.25	0.76	2737	0.92	1.26	4524	0.67
0.60	0.07	244	5.15	0.12	433	3.59	0.19	677	2.72	0.32	1144	1.96	0.51	1843	1.45	0.83	2986	1.08	1.37	4935	0.79
0.65	0.07	264	5.92	0.13	469	4.13	0.20	733	3.13	0.34	1240	2.25	0.56	1997	1.67	0.90	3234	1.24	1.49	5347	0.90
0.70	0.08	284	6.74	0.14	506	4.71	0.22	790	3.56	0.37	1335	2.56	0.60	2150	1.90	0.97	3483	1.41	1.60	5758	1.03
0.75	0.08	305	7.61	0.15	542	5.31	0.24	846	4.02	0.40	1430	2.89	0.64	2304	2.15	1.04	3732	1.59	1.72	6169	1.16
0.80	0.09	325	8.52	0.16	578	5.94	0.25	903	4.50	0.42	1526	3.24	0.68	2458	2.41	1.11	3981	1.78	1.83	6581	1.30
0.85	0.10	345	9.47	0.17	614	6.61	0.27	959	5.00	0.45	1621	3.60	0.73	2611	2.67	1.18	4230	1.98	1.95	6992	1.44
0.90	0.10	366	10.47	0.18	650	7.31	0.28	1016	5.53	0.48	1716	3.98	0.77	2765	2.96	1.25	4479	2.19	2.06	7403	1.60
0.95	0.11	386	11.51	0.19	686	8.03	0.30	1072	6.08	0.50	1812	4.38	0.81	2918	3.25	1.32	4727	2.40	2.17	7815	1.76
1.00	0.11	406	12.59	0.20	722	8.78	0.31	1128	6.65	0.53	1907	4.79	0.85	3072	3.55	1.38	4976	2.63	2.29	8226	1.92
1.10	0.12	447	14.87	0.22	794	10.38	0.35	1241	7.85	0.58	2098	5.66	0.94	3379	4.20	1.52	5474	3.11	2.52	9048	2.27
1.20	0.14	487	17.32	0.24	867	12.09	0.38	1354	9.14	0.64	2288	6.59	1.03	3686	4.89	1.66	5971	3.62	2.75	9871	2.64
1.30	0.15	528	19.92	0.26	939	13.90	0.41	1467	10.52	0.69	2479	7.58	1.11	3994	5.62	1.80	6469	4.16	2.98	10694	3.04
1.40	0.16	569	22.68	0.28	1011	15.83	0.44	1580	11.98	0.74	2670	8.63	1.20	4301	6.40	1.94	6967	4.74	3.20	11516	3.46
1.50	0.17	609	25.59	0.30	1083	17.86	0.47	1693	13.51	0.80	2860	9.73	1.28	4608	7.23	2.08	7464	5.35	3.43	12339	3.90
1.60	0.18	650	28.65	0.32	1155	19.99	0.50	1805	15.13	0.85	3051	10.90	1.37	4915	8.09	2.22	7962	5.98	3.66	13161	4.37
1.70	0.19	691	31.85	0.34	1228	22.23	0.53	1918	16.82	0.90	3242	12.12	1.45	5222	9.00	2.35	8459	6.65	3.89	13984	4.86
1.80	0.20	731	35.21	0.36	1300	24.57	0.57	2031	18.59	0.96	3433	13.39	1.54	5530	9.94	2.49	8957	7.35	4.12	14806	5.37
1.90	0.21	772	38.70	0.38	1372	27.01	0.60	2144	20.44	1.01	3623	14.72	1.62	5837	10.93	2.63	9455	8.08	4.35	15629	5.86
2.00	0.23	812	42.33	0.40	1444	29.55	0.63	2257	22.36	1.06	3814	16.10	1.71	6144	11.95	2.77	9952	8.84	4.58	16452	6.43
2.10	0.24	853	46.11	0.42	1517	32.18	0.66	2370	24.35	1.11	4005	17.54	1.80	6451	13.02	2.91	10450	9.63	4.81	17274	7.02
2.20	0.25	894	50.02	0.44	1589	34.91	0.69	2482	26.41	1.17	4195	19.03	1.88	6758	14.12	3.05	10947	10.45	5.04	18097	7.64
2.30	0.26	934	54.06	0.46	1661	37.73	0.72	2595	28.55	1.22	4386	20.57	1.97	7066	15.27	3.18	11445	11.29	5.26	18919	8.27
2.40	0.27	975	58.24	0.48	1733	40.65	0.75	2708	30.76	1.27	4577	22.16	2.05	7373	16.45	3.32	11943	12.06	5.49	19742	8.94
2.50	0.28	1016	62.56	0.50	1805	43.66	0.79	2821	33.03	1.33	4767	23.80	2.14	7680	17.66	3.46	12440	12.98	5.72	20565	9.62
2.60	0.29	1056	67.00	0.52	1878	46.76	0.82	2934	35.38	1.38	4958	25.49	2.22	7987	18.92	3.60	12938	13.94	5.95	21387	10.33
2.70	0.31	1097	71.58	0.54	1950	49.96	0.85	3047	37.80	1.43	5149	27.23	2.31	8294	20.21	3.74	13436	14.92	6.18	22210	11.06
2.80	0.32	1137	76.28	0.56	2022	53.24	0.88	3159	40.28	1.49	5339	29.02	2.39	8602	21.54	3.88	13933	15.93	6.41	23032	11.81
2.90	0.33	1178	81.11	0.58	2094	56.61	0.91	3272	42.83	1.54	5530	30.86	2.48	8909	22.90	4.02	14431	16.98	6.64	23855	12.59
3.00	0.34	1219	86.07	0.60	2166	60.07	0.94	3385	45.45	1.59	5721	32.74	2.56	9216	24.30	4.15	14928	18.05	6.87	24677	13.38
3.60	0.41	1462	118.42	0.72	2600	82.65	1.13	4062	62.53	1.91	6865	45.05	3.08	11059	33.46	4.99	17914	25.10	8.24	29613	18.62
4.00	0.45	1625	142.39	0.80	2889	99.38	1.26	4513	75.19	2.12	7628	53.79	3.42	12288	40.48	5.54	19904	30.38	9.16	32903	22.53
4.60	0.52	1869	181.85	0.92	3322	126.92	1.44	5191	96.03	2.44	8772	69.25	3.93	14131	52.12	6.37	22890	39.13	10.53	37839	29.03
5.00	0.57	2031	210.42	1.00	3611	146.86	1.57	5642	111.11	2.65	9535	80.51	4.27	15360	60.61	6.92	24881	45.51	11.45	41129	33.78

Pressure loss of sanitary press fittings

Chart	Symbol	Zeta Factor							
		Dim. 16	Dim. 20	Dim. 26	Dim. 32	Dim. 40	Dim. 50	Dim. 63	
T-piece Dividing flow		13,5	6,3	5,5	3,5	2,8	1,3	0,8	
T-piece connecting (coupling)		6,6	2,1	1,7	1,1	0,8	0,5	0,4	
T-piece reverse Dividing flow		6,3	2,6	2,3	2,1	1,7	1,0	0,7	
T-piece reverse Merging flow		12,2	8,5	6,8	5,1	3,4	2,8	2,2	
Elbow 90°		13,5	6,2	6,0	4,3	3,1	1,5	1,1	
Pipe angle		1,3	0,9	0,7	0,4	0,2	-	-	
Reduced socket		8,3	6,9	2,8	2,1	1,2	0,9	0,6	
Shear wall		10,6	8,8	5,2	-	-	-	-	

### Technical Instructions: Heating

Pressure loss for Presstite pipe Dim. 16 / 20 / 26 / 32 / 40 / 50 / 63

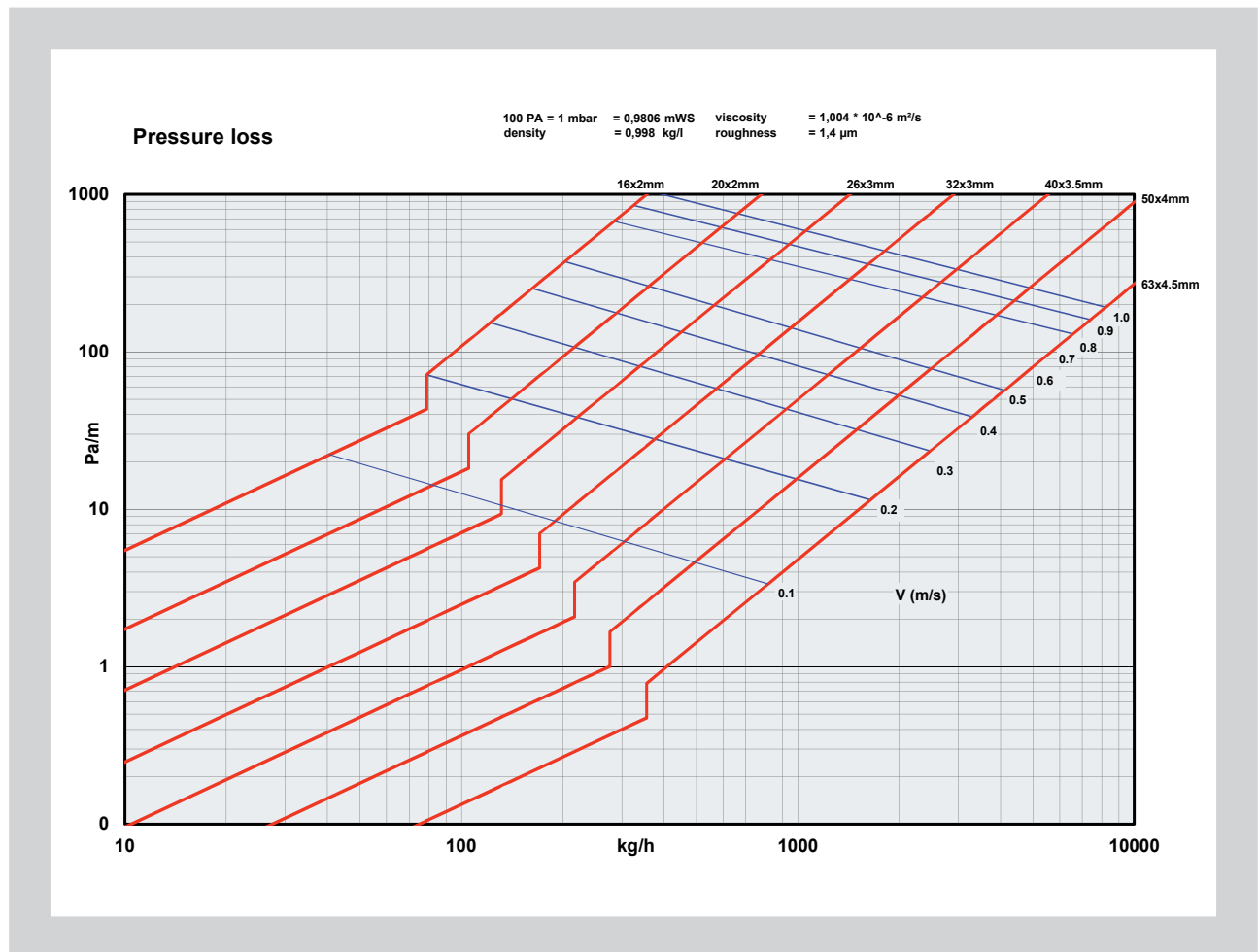

Pressure loss of heating press fittings

Chart	Symbol	Zeta Factor						
		Dim. 16	Dim. 20	Dim. 26	Dim. 32	Dim. 40	Dim. 50	Dim. 63
T-piece Dividing flow		13,5	6,3	5,5	3,5	2,8	1,3	0,8
T-piece connecting (coupling)		6,6	2,1	1,7	1,1	0,8	0,5	0,4
T-piece reverse Dividing flow		6,3	2,6	2,3	2,1	1,7	1,0	0,7
T-piece reverse Merging flow		12,2	8,5	6,8	5,1	3,4	2,8	2,2
Elbow 90°		13,5	6,2	6,0	4,3	3,1	1,5	1,1
Pipe angle		1,3	0,9	0,7	0,4	0,2	-	-
Reduced socket		8,3	6,9	2,8	2,1	1,2	0,9	0,6
Shear wall		10,6	8,8	5,2	-	-	-	-





### Calculation and tender

Generally an easy calculation with Presstite Sanitary is possible. The different pipe dimensions are listed. Fittings, couplings and fixing device have to be specified separately.

The subsequent times and their additional fees can be set up for calculation in the appropriate positions.

Surcharge for assembly time

Assembly times (indicative times) result from the performance of one group (installer and assistant) and are recorded in minute time units. By help of these mounting times it is possible to determine the necessary processing times for the Presstite system.

This includes e.g.: to provide the material, tool and other device on the construction site, to study the floor plan, measuring pipes, marking, cut into lengths, forming to size, burring and clamping. Other performances like extend and kind of construction project and as well the season or distance to work shop are not included in the following chart. These additional performances should

### Assembly time per linear meters incl. fittings

Minutes (installer and assistant)	10	11	13	15	16	18
e.g. 46 Euro/h group salary (installer and assistant) Euro/m	7,67	8,43	9,97	11,50	12,27	13,80
Pipe diameter	Dim. 14/16	Dim. 20	Dim. 26	Dim. 32	Dim. 40	Dim. 50/63

### Additional surcharge in percentage

This surcharge includes the material of fittings. It is added on the entire pipe installation (only costs for material). The surcharge is only a recommendation and depends on the performance.

### Fitting surcharge (for single-family houses and apartment buildings)

100 % by use of pipe bending tools for all dimensions

120 % by use of elbows for every change of direction

### Example for fitting surcharge

#### with 100 % surcharge

- long pipe routes
- small fitting use
- bended direction change

#### with 120 % surcharge

- short pipe routes
- high fitting use
- direction change with elbows

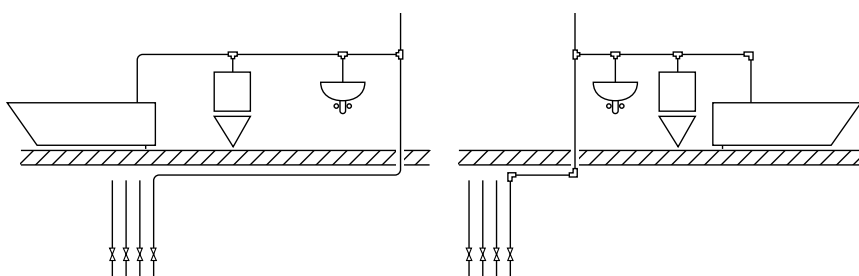

### Assembly time per linear meter and fittings in minutes

Dimension	16	20	26	32	40	50	63
Pipe (without fitting)	7	8	10	12	13	14	14
Shear wall	4	4	4	-	-	-	-
Elbow	1,5	1,5	2	2,5	3	4	4
T-piece	2	2	2,5	3	4	5	5
Connectors/ couplings	1,5	1,5	2	2,5	3	4	4
Screw connections	1,5	2	2	2	3	4	4

Basis for calculation of a differentiated assembly time is the appropriate biggest dimension of fitting.

### Example T-piece 26-32-26

Pipe diameter	16,0 x 2,0	20,0 x 2,0	26 x 3	32 x 3	40 x 3,5	50 x 4	63 x 4
T-piece	2	2	2,5	3	4	5	5

# Connecting Pipe & Fittings

1



1 Cut the pipe square using the specially designed Presstite Cutter.

2



2 Use the correct size Presstite Deburring Tool to chamfer the pipe to create the required bevel for the press fitting to be installed.

3

3 Ensure the fitting is clean and all the components are in correct position. Push pipe into the fitting until it reaches the fitting end. The fitting will show a window and when the pipe is correctly inserted the pressing sleeve is in correct position.

4

4 Close the correctly chosen press-fit jaw tightly around the fitting. Turn on the gun on by pressing the trigger and holding. The pressing process is completed as soon as the pressing jaws are completely closed. When the fitting is complete a change in sound will occur with the press tool. Open the press-fit jaws and remove the pressed fitting.

3



4



## KEY POINTS

- Only Presstite trained personnel to carry out installation of Presstite Multilayer.
- A Presstite joint should only require one attempt.
- The jaws will not release until the required pressure has been applied.
- Press fitting must be free from dirt and damage.
- All Press-tools must be calibrated as per manufactures recommendations.

MULTILAYER PIPE PEX<sub>c</sub>/AL/PEX<sub>c</sub> (BUTT WELDED) 95°C / 10 BAR



TYPE	ALUMINIUM THICKNESS (MM)	PRODUCT CODE
16 x 2mm (100MT COIL)	0.4	920100002
16 x 2mm (5MT LNS)	0.4	920005002
20 x 2mm (100MT COIL)	0.5	920100003
20 x 2mm (5MT LNS)	0.5	920005003
26 x 3mm (50MT COIL)	0.6	920050004
26 x 3mm (5MT LNS)	0.6	920005004
32 x 3mm (50MT COIL)	0.8	920050005
32 x 3mm (5MT LNS)	0.8	920005005
40 x 3.5mm (5MT LNS)	1.0	920005006
50 x 4mm (5MT LNS)	1.2	920005007
63 x 4.5mm (5MT LNS)	1.5	920005008

MULTILAYER PIPE PEX<sub>b</sub>/AL/PEX<sub>b</sub> (OVERLAPPED) 95°C / 10 BAR C/W 10MM INSULATION



TYPE	ALUMINIUM THICKNESS (MM)	PRODUCT CODE
16 x 2mm (50MT COIL)	0.2	930050002
16 x 2mm (100MT COIL)	0.2	930100002
20 x 2mm (50MT COIL)	0.25	930050003
26 x 3mm (50MT COIL)	0.3	930050004
32 x 3mm (25MT COIL)	0.4	930025005

MULTILAYER PIPE PEX<sub>c</sub>/AL/PEX<sub>c</sub> (BUTT WELDED) 95°C 10 BAR C/W CORRUGATED PROTECTIVE SLEEVE



TYPE	ALUMINIUM THICKNESS (MM)	PRODUCT CODE
16 x 2mm (100MT COIL)	0.4	940100001
20 x 2mm(100MT COIL)	0.5	940100002

MULTILAYER PIPE PE-HD/AL/PE-MD (BUTT WELDED) 70°C / 6 BAR FOR UNDER FLOOR HEATING ONLY



TYPE	ALUMINIUM THICKNESS (MM)	PRODUCT CODE
16 x 2mm (200MT COIL)	0.2	PEALPE 16X200
16 x 2mm (500MT COIL)	0.2	PEALPE 16X500

## EQUAL COUPLING



TYPE	PRODUCT CODE
16 x 2 - 16 x 2	900310002
20 x 2 - 20 x 2	900310003
26 x 3 - 26 x 3	900310004
32 x 3 - 32 x 3	900310005
40 x 3,5 - 40 x 3,5	900310006
50 x 4 - 50 x 4	900310007
63 x 4,5 - 63 x 4,5	900310008

## REDUCER



TYPE	PRODUCT CODE
20 x 2 - 16 x 2	900310032
26 x 3 - 16 x 2	900310042
26 x 3 - 20 x 2	900310043
32 x 3 - 16 x 2	900310052
32 x 3 - 20 x 2	900310053
32 x 3 - 26 x 3	900310054
40 x 3,5 - 26 x 3	900310064
40 x 3,5 - 32 x 3	900310065
50 x 4 - 26 x 3	900310074
50 x 4 - 32 x 3	900310075
50 x 4 - 40 x 3,5	900310076
63 x 4,5 - 26 x 3	900310084
63 x 4,5 - 32 x 3	900310085
63 x 4,5 - 40 x 3,5	900310086
63 x 4,5 - 50 x 4	900310087

## MALE ADAPTER



TYPE	PRODUCT CODE
16 x 2 - 1/2"	900311023
20 x 2 - 1/2"	900311003
20 x 2 - 3/4"	900311034
26 x 3 - 3/4"	900311004
26 x 3 - 1"	900311045
32 x 3 - 1"	900311005
32 x 3 - 1 1/4"	900311056
40 x 3,5 - 1"	900311065
40 x 3,5 - 1 1/4"	900311006
50 x 4 - 1 1/4"	900311076
50 x 4 - 1 1/2"	900311007
63 x 4,5 - 2"	900311008

## FEMALE ADAPTER



TYPE	PRODUCT CODE
16 x 2 - 1/2"	900312023
20 x 2 - 1/2"	900312003
20 x 2 - 3/4"	900312034
26 x 3 - 3/4"	900312004

FEMALE ADAPTER CONTINUED



TYPE	PRODUCT CODE
26 x 3 - 1"	900312045
32 x 3 - 1"	900312005
32 x 3 - 1 1/4"	900312056
40 x 3,5 - 1"	900312065
40 x 3,5 - 1 1/4"	900312006
50 x 4 - 1 1/4"	900312076
50 x 4 - 1 1/2"	900312007
63 x 4,5 - 2"	900312008

90° ELBOW



TYPE	PRODUCT CODE
16 X 2	900315002
20 X 2	900315003
26 X 3	900315004
32 X 3	900315005
40 X 3.5	900315006
50 X 4	900315007
63 X 4.5	900315008

45° ELBOW



TYPE	PRODUCT CODE
26 x 3	900315104
32 x 3	900315105
40 x 3,5	900315106
50 x 4	900315107
63 x 4,5	900315108

90° ELBOW MALE THREAD



TYPE	PRODUCT CODE
16 x 2 - 1/2"	900316023
20 x 2 - 1/2"	900316003
20 x 2 - 3/4"	900316034
26 x 3 - 3/4"	900316004
32 x 3 - 1"	900316005
40 x 3,5 - 1 1/4"	900316006
50 x 4 - 1 1/4"	900316076
50 x 4 - 1 1/2"	900316007
63 x 4,5 - 2"	900316008



## 90° ELBOW FEMALE THREAD



TYPE	PRODUCT CODE
16 x 2 - 1/2"	900317023
20 x 2 - 1/2"	900317003
20 x 2 - 3/4"	900317034
26 x 3 - 3/4"	900317004
32 x 3 - 1"	900317005
40 x 3,5 - 1 1/4"	900317006
50 x 4 - 1 1/4"	900317076
50 x 4 - 1 1/2"	900317007
63 x 4,5 - 2"	900317008

## EQUAL TEES



TYPE	PRODUCT CODE
16 x 2	900318002
20 x 2	900318003
26 x 3	900318004
32 x 3	900318005
40 x 3,5	900318006
50 x 4	900318007
63 x 4,5	900318008

## REDUCED BRANCH TEES



TYPE	PRODUCT CODE
20 x 2 - 16 x 2 - 20 x 2	900318323
26 x 3 - 16 x 2 - 26 x 3	900318424
26 x 3 - 20 x 2 - 26 x 3	900318434
32 x 3 - 16 x 2 - 32 x 3	900318525
32 x 3 - 20 x 2 - 32 x 3	900318535
32 x 3 - 26 x 3 - 32 x 3	900318545
40 x 3,5 - 26 x 3 - 40 x 3,5	900318646
40 x 3,5 - 32 x 3 - 40 x 3,5	900318656
50 x 4 - 26 x 3 - 50 x 4	900318747
50 x 4 - 32 x 3 - 50 x 4	900318757
50 x 4 - 40 x 3,5 - 50 x 4	900318767
63 X 4.5 - 40 X 3.5 - 63 X 4.5	900318868
63 X 4.5 - 50 X 4 - 63 X 4.5	900318878

INCREASED BRANCH TEES



TYPE	PRODUCT CODE
16 x 2 - 20 x 2 - 16 x 2	900318232
20 x 2 - 26 x 3 - 20 x 2	900318343
26 x 3 - 32 x 3 - 26 x 3	900318454
32 x 3 - 40 x 3,5 - 32 x 3	900318565
40 x 3,5 - 50 x 3,5 - 40 x 3,5	900318676

REDUCING TEES



TYPE	PRODUCT CODE
20 x 2 - 16 x 2 - 16 x 2	900318322
20 x 2 - 20 x 2 - 16 x 2	900318332
26 x 3 - 16 x 2 - 20 x 2	900318423
26 x 3 - 20 x 2 - 16 x 2	900318432
26 x 3 - 20 x 2 - 20 x 2	900318433
26 x 3 - 26 x 3 - 16 x 2	900318442
26 x 3 - 26 x 3 - 20 x 2	900318443
32 x 3 - 20 x 2 - 26 x 3	900318534
32 x 3 - 26 x 3 - 26 x 3	900318544
32 x 3 - 32 x 3 - 20 x 2	900318553
32 x 3 - 32 x 3 - 26 x 3	900318554
40 x 3,5 - 32 x 3 - 32 x 3	900318655
40 x 3,5 - 26 x 3 - 32 x 3	900318645
40 x 3,5 - 40 x 3,5 - 26 x 3	900318664
40 x 3,5 - 40 x 3,5 - 32 x 3	900318665
50 x 4 - 40 x 3,5 - 40 x 3,5	900318766
50 x 4 - 32 x 3 - 40 x 3,5	900318756
50 x 4 - 50 x 4 - 32 x 3	900318775
50 x 4 - 50 x 4 - 40 x 3,5	900318776

TEE WITH FEMALE THREAD ON BRANCH



TYPE	PRODUCT CODE
16 x 2 - 1/2" - 16 x 2	900330023
20 x 2 - 1/2" - 20 x 2	900330033
20 x 2 - 3/4" - 20 x 2	900330034
26 x 3 - 1/2" - 26 x 3	900330043
26 x 3 - 3/4" - 26 x 3	900330004
32 x 3 - 1/2" - 32 x 3	900330053
32 x 3 - 3/4" - 32 x 3	900330054
32 x 3 - 1" - 32 x 3	900330005

## TEE WITH FEMALE THREAD ON BRANCH CONTINUED



TYPE	PRODUCT CODE
32 x 3 - 1 1/4" - 32 x 3	900330056
40 x 3,5 - 1" - 40 x 3,5	900330065
40 x 3,5 - 1 1/4" - 40 x 3,5	900330006
50 x 4 - 1 1/2" - 50 x 4	900330007
63 x 4,5 - 2" - 63 x 4,5	900330008

## LEVER ACTION BALL VALVE



TYPE	PRODUCT CODE
16mm	900346002
20mm	900346003
26mm	900346004

## WALL PLATE ELBOW



TYPE	PRODUCT CODE
16 x 2 - 1/2"	900307023
20 x 2 - 1/2"	900307003
20 x 2 - 3/4"	900307034
26 x 3 - 3/4"	900307004

## RADIATOR UPSTAND 300MM



TYPE	PRODUCT CODE
16 x 2 - 15 mm	900325002

## STAINLESS STEEL MANIFOLDS / 6 BAR



TYPE	PRODUCT CODE
Presstite 2 Way Manifolds	9442
Presstite 3 Way Manifolds	9443
Presstite 4 Way Manifolds	9444
Presstite 5 Way Manifolds	9445
Presstite 6 Way Manifolds	9446
Presstite 7 Way Manifolds	9447
Presstite 8 Way Manifolds	9448
Presstite Ball Valve 1",1"	500300005
Presstite Ball Valve 1",3/4"	500300045
Presstite Union 16 x 2mm	950378012
Presstite Union 20 x 2mm	950378013
Presstite Swivel Union 16 x 3/4"	900104124
Presstite Swivel Union 20 x 3/4"	900104134

**BATTERY HYDRAULIC PRESSING TOOL SPM32**



SIZE	PRODUCT CODE
14 - 75mm	900400000

**ACCESSORIES FOR SPM32**



SIZE	PRODUCT CODE
Additional Battery	900410001
230 Volt Charger	900410002

**PRESSING JAW KSP11 FOR SPM32**



SIZE	PRODUCT CODE
16mm	900401002
20mm	900401003
26mm	900401004
32mm	900401005
40mm	900401006

**PRESSING JAW KSP11 FOR SPM32**



SIZE	PRODUCT CODE
50mm	900401007
63mm	900401008

**PRESSTITE MP22 MECHANICAL PRESSTOOL**



SIZE	PRODUCT CODE
16 - 26mm	900420000

**JAW INSERTS FOR MP22 MECHANICAL PRESS TOOL**



SIZE	PRODUCT CODE
16mm	900421002
20mm	900421003
26mm	900421004

## BATTERY HYDRAULIC PRESSING TOOL MAP 1



SIZE	PRODUCT CODE
16 - 32mm	900410000
16 - 32mm Jaws Included	900410100

## ACCESSORIES FOR MAP 1



SIZE	PRODUCT CODE
Additional Battery	900400001
230 Volt Charger	900400002

## PRESSING JAW KSP11 FOR MAP 1



SIZE	PRODUCT CODE
16mm	900411002
20mm	900411003
26mm	900411004
32mm	900411005

## DEBURRING TOOL



SIZE	PRODUCT CODE
16mm	900572002
20mm	900572003
26mm	900572004
32mm	900572005
40mm	900572006
50mm	900572007
63mm	900572008

## OUTER BENDING SPRING



SIZE	PRODUCT CODE
16mm	900573002
20mm	900573003
26mm	900573004
32mm	900573005

## INNER BENDING SPRING



SIZE	PRODUCT CODE
16mm	900574002
20mm	900574003
26mm	900574004

EASY BEND TOOL



SIZE

PRODUCT CODE

16mm

900460002

20mm

900460003

PIPE CUTTERS



SIZE

PRODUCT CODE

6 - 67mm

900440002

50 - 140mm

900440003

PIPE SHEARS



SIZE

PRODUCT CODE

0 - 35mm

900450002

PIPE STRAIGHTENERS



SIZE

PRODUCT CODE

0 - 26mm

900403001

Adaptor For Reel

900403002

DE-COILER



SIZE

PRODUCT CODE

4 Arm Pipe Reel

900404001



## CORRUGATED PIPE CUTTERS



SIZE	PRODUCT CODE
0 - 26mm	900430001

## PIPE SHEARS



SIZE	PRODUCT CODE
0 - 42mm	900450001

## PIPE SHEARS



SIZE	PRODUCT CODE
0 - 63mm	900450003

## DE - COILER



SIZE	PRODUCT CODE
200m Coil (Wheelable)	900404002
600m Coil (Wheelable)	900404003

## PIPE CLIPS



SIZE	PRODUCT CODE
16 x 2mm Pipe Clip	900426002
20 x 2mm Pipe Clip	900426003
26 x 3mm Pipe Clip	900426004
32 x 3mm Pipe Clip	900426005
40 x 3.5mm Pipe Clip	900426006
50 x 4mm Pipe Clip	900426007
63 x 4.5mm Pipe Clip	900426008

COUPLING



SIZE	PRODUCT CODE
16 x 2 - 16 x 2	910310002
20 x 2 - 20 x 2	910310003
26 x 3 - 26 x 3	910310004
32 x 3 - 32 x 3	910310005
20 X 2 - 16 X 2	910310032

MALE ADAPTOR



SIZE	PRODUCT CODE
16 x 2 - 1/2"	910311023
20 x 2 - 1/2"	910311003
16 x 2 - 3/4"	910311024
20 x 2 - 3/4"	910311034
26 x 3 - 3/4"	910311004
26 x 3 - 1"	910311045
32 x 3 - 1"	910311005

FEMALE ADAPTOR



SIZE	PRODUCT CODE
16 x 2 - 1/2"	910312023
20 x 2 - 1/2"	910312003
16 x 2 - 3/4"	910312024
20 x 2 - 3/4"	910312034
26 x 3 - 3/4"	910312004
26 x 3 - 1"	910312045
32 x 3 - 1"	910312005

90° ELBOW



SIZE	PRODUCT CODE
16 X 2	910315002
20 X 2	910315003
26 X 3	910315004
32 X 3	910315005

90° ELBOW MALE THREAD



SIZE	PRODUCT CODE
16 x 2 - 1/2"	910316023
20 x 2 - 1/2"	910316003
20 x 2 - 3/4"	910316034
26 x 3 - 3/4"	910316004
26 x 3 - 1"	910316045
32 x 3 - 1"	910316005

90° ELBOW FEMALE THREAD



SIZE	PRODUCT CODE
16 x 2 - 1/2"	910317023
20 x 2 - 1/2"	910317003
20 x 2 - 3/4"	910317034
26 x 3 - 3/4"	910317004
26 x 3 - 1"	910317045
32 x 3 - 1"	910317005

WALL PLATE ELBOW



SIZE	PRODUCT CODE
16 x 2 - 1/2"	910307023
20 x 2 - 1/2"	910307003

## EQUAL TEES



SIZE	PRODUCT CODE
16 x 2	910318002
20 x 2	910318003
26 x 3	910318004
32 x 3	910318005

## REDUCED BRANCH TEES



SIZE	PRODUCT CODE
16 x 2 X 16 x 2 X 20 x 2	910318223
16 x 2 X 20 x 2 X 20 x 2	910318233
20 x 2 X 16 x 2 X 20 x 2	910318323
26 x 3 X 16 x 2 X 26 x 3	910318424
26 x 3 X 20 x 2 X 26 x 3	910318434
32 x 3 X 26 x 3 X 32 x 3	910318545

## TEE WITH MALE THREAD ON BRANCH



SIZE	PRODUCT CODE
16 x 2 - 1/2"	910331023
20 x 2 - 1/2"	910331003
20 x 2 - 3/4"	910331034
26 x 3 - 3/4"	910331004
26 x 3 - 1"	910331045
32 x 3 - 1"	910331005

## TEE WITH FEMALE THREAD ON BRANCH



SIZE	PRODUCT CODE
16 x 2 - 1/2"	910330023
20 x 2 - 1/2"	910330003
20 x 2 - 3/4"	910330034
26 x 3 - 3/4"	910330004
26 x 3 - 1"	910330045
32 x 3 - 1"	910330005

## MANIFOLDS



SIZE	PRODUCT CODE
2-Way Manifold c/w Adapters	910200002
3-Way Manifold c/w Adapters	910200003
4-Way Manifold c/w Adapters	910200004
3/4" Nickle Blank Cap	910372004

## SPARE RING



SIZE	PRODUCT CODE
16 mm	910378B002
20 mm	910378B003
26 mm	910378B004
32 mm	910378B005

## COPPER ADAPTORS



SIZE	PRODUCT CODE
16 mm - 1/2" Irish Copper Adapter	910378023
16 mm - 15mm English Copper Adapter	910378123







**POLYCOMFORT®**  
THE PRE-CAST UNDERFLOOR HEATING SYSTEM

TECHNICAL CATALOGUE  
EFFECTIVE FROM 17 JANUARY 2019

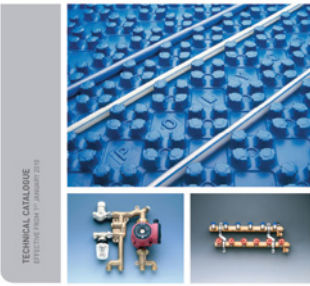

**Polytherm**  
Heating Systems Ltd.

**HEATRACK®**  
THE EASIEST AND CLEANEST WAY TO INSTALL AN UNDER-FLOOR HEATING SYSTEM

PRODUCT OVERVIEW  
EFFECTIVE FROM 17 JANUARY 2019



**Polytherm**  
Heating Systems Ltd.

**CALPEX®**  
PRE-INSULATED PIPING SYSTEM

PRODUCT OVERVIEW  
EFFECTIVE FROM 17 JANUARY 2019



**Polytherm**  
Heating Systems Ltd.

**CASAFLEX®**  
HIGH TEMPERATURE PRE-INSULATED PIPING SYSTEM

PRODUCT OVERVIEW  
EFFECTIVE FROM 17 JANUARY 2019



**Polytherm**  
Heating Systems Ltd.

**Polytherm Heating Systems Ltd**  
Muirfield Drive  
Naas Road  
Dublin 12  
Ireland  
T +353 1 419 1990  
F +353 1 458 4808  
E info@polytherm.ie  
W www.polytherm.ie

**Polytherm Heating Systems Ltd**  
Furry Park Industrial Estate  
Santry  
Dublin 9  
Ireland  
T +353 1 842 7037  
F +353 1 842 7045  
E info@polytherm.ie  
W www.polytherm.ie

**Polytherm Heating Systems Ltd**  
South Ring West Business Park  
Tramore Road  
Cork  
Ireland  
T +353 21 432 1066  
F +353 21 432 1068  
E info@polytherm.ie  
W www.polytherm.ie